

Date: _____ Customer: _____

Project: _____

Type: _____ Qty: _____



Piix™ MRC

LED Linear Direct/Indirect



Order Code:	PXLDI											
PXLDI	Series											
	PXLDI Piix™ MRC (Micro Reflector Cell) LED Linear Direct/Indirect											
Direct Light Engine	1B45^{1,2} 1150lm/10.9W per foot	1B40^{1,2} 1045lm/9.7W per foot	1B30¹ 803lm/7.4W per foot	1B20¹ 543lm/4.9W per foot							¹ Values calculated from a 4' fixture at 4000K, 90+ CRI using 35° (wide) reflector, no secondary optics and DIM driver	
Indirect Light Engine	1C35³ 701lm/8.7W per foot	1C30³ 627lm/7.3W per foot	1C25³ 500lm/6.1W per foot	1C20³ 415lm/4.9W per foot							³ Values calculated from a 4' fixture at 90 CRI, 3500K with ID lens and DIM driver.	
CCT	927 2700K 90+ CRI	930 3000K 90+ CRI	935 3500K 90+ CRI	940 4000K 90+ CRI	TW 2700K-6500K My White 90+ CRI (consult factory)							² CCT selected will apply to both direct and indirect distributions.
Direct Optics	10 10° Very Narrow (beam angle 20°)	20 20° Narrow (beam angle 40°)	35 35° Medium (beam angle 70°)	50 50° Wide (beam angle 100°)								
Secondary Optics	CL Clear Lens (defined edge)	DF 30% Diffuse Lens (soft edge)	LF 5% Lightly Diffuse Lens (soft edge)	HX Hexcell Louver	XX No Secondary Optics (defined edge)							
Baffle Finish	PW Matte White	PB Matte Black										
Indirect Shielding	ID Indirect Diffuse Optic	IB Indirect Batwing Optic										
Mounting	C Cable	S Swivel Stem	RS Rigid Stem	W Wall Mount								
Nominal Fixture Length	02 2 ft.	03 3 ft.	04 4 ft.	05 5 ft.	06 6 ft.	07 7 ft.	08 8 ft.	XX	22'	For Luminaires with OAL >8', round up to the nearest foot and replace the "xx" with the #, note exact OAL on fixture schedule. For luminaires with OAL <8', please consult factory.		
Finish	WH White	BL Semi-Matte Black	SV Silver	SP Specify Premium Color							[*] Custom colors are available, please consult factory	
Voltage	1 120V	2 277V	U 120V through 277V 50/60Hz capable	3 347V (consult factory)								
Driver	DIM⁴ 0-10V 1% (Linear)	DIL⁴ eldoLED 1% ECOdrive 0-10V (Logarithmic)	DED⁴ eldoLED 1% ECOdrive DALI (Logarithmic)	D01⁴ eldoLED 0.1% SOLdrive 0-10V (Linear)	DL01⁴ eldoLED 0.1% SOLdrive 0-10V (Logarithmic)	DC2^{4,5} Lutron 1% 2-Wire	DE1⁴ Lutron 1% Eco-System	DC3 Lutron 1% 3-Wire (consult factory)				⁴ See page 6 for full details ⁵ 120V only
Fixture Options	FS In-line Fuse	SS Separate Switching										
Sensor Options	xE Enlighted (consult factory) Replace "x" with quantity	xS1^{6,7} Sensor Switch Daylight	xS2^{6,7} Sensor Switch Occ/Vac	xS3^{6,7} Sensor Switch Occ/Vac/Daylight	xSN nLight Enabled (consult factory)	xV Lutron Vive (consult factory)						⁶ See page 9 for full details and restrictions ⁷ For use with DIM or DIL driver only
Emergency Options	EC Emergency Circuit Wiring	EMR Remote Micro inverter (consult)	EM^{8,9,10} Integral EM Battery Pack									⁸ See page 8 for full details and restrictions ⁹ For EM with sensors please consult factory ¹⁰ EM available in 4' and ≥6'. Please consult factory for 5'.
Configuration Options	L9¹¹ Horizontal 90° Corner	T9¹¹ Lit "T" section	X9¹¹ Lit "X" section									¹¹ See page 11 for full details and restrictions



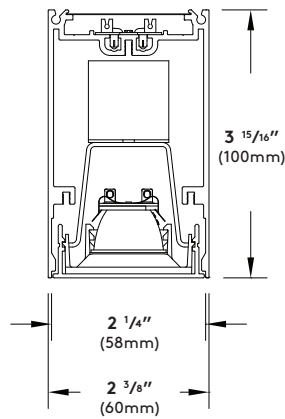

Construction:

Housing - Continuous, low copper 6063-T6 extruded aluminum profile with aluminum endcaps, available as Individual fixtures (up to 8') or Runs.

Faceplate - Extruded aluminum profile with laser cut cells for accuracy.

Baffles - Injection molded nylon material with a semi-matte Black or White finish.

Reflectors - Precision-designed, injection molded polycarbonate material for accurate distributions and powerful lighting effects. Four different distributions available - 10° Very Narrow (20° beam angle), 20° Narrow (40° beam angle), 35° Medium (70° beam angle), or 50° Wide (100° beam angle).

Optional Optics - Clear Lens (CL), Diffuse Lens (DF), Lightly Diffuse Lens (LF), or Hexcell Louver (HX), snaps in behind the baffle. Optics cannot be combined within the same cell.

Indirect Optics - Indirect Diffuse Optic (ID) is diffuse lensing sheet that secures in features of the extrusion. Indirect Batwing Optic (IB) is lensing sheet that secures in features of the extrusion.

Mounting(s) - 3/64" Aircraft Cable, Ø5/8" Swivel or Rigid Steel Stem, Wall Bracket (see pages 3 through 6 for details). Aircraft cables (C) are adjustable along the length of the fixture, but should not be moved more than 6" from ends to allow for proper support.

Standard Luminaire Lengths - All standard luminaires are supplied in nominal lengths to ensure even distribution of optical cells. Runs and Configurations are available in approximately 2' increments (due to MRC size) starting at the nominal 8' fixture length. **Individual luminaires are not joinable in the field.

Exact Length Luminaires - Individual luminaires, Runs, and Configurations are available to meet your project needs. Please consult factory with your requirements.

PX Joiner - Runs and Configurations are supplied in multiple housings that are joined together in the field using the supplied PX Joiner system. This allows ease of installation (see page 7 for details).

Weight - 2.5 lb. per foot

Electrical/Performance:

LED Light Engine - Brand-name mid-power LEDs create a high efficiency LED light engine with a reported lumen maintenance of 97.3% at 10,000 hours, 180 mA drive current and >55°C case temperature. Calculated L80 lumen maintenance of > 60,000 hours @ 25°C. Lumen maintenance values calculated in accordance to TM-21 procedures based on LM-80 compliant reported measurement data. For Title 24 compliant model numbers, please consult factory.

Photometrics - Consult website or factory for IES Files. Photometric lumen measurement complies with IES LM-79-08 testing procedures. Due to the LED manufacturer's tolerances, the listed output has a ±5% tolerance. For outputs based on different optics or CCT, please see pages 12-16 for details.

CCT - Available in 2700K, 3000K, 3500K, and 4000K, tolerance within a 3-step MacAdam ellipse. My White Tunable White (TW) 2700K-6500K available - consult factory.

CRI - 90+.

All Drivers - High efficient, constant current, soft start, Electronic Class 2 with a PFC>0.90. For more detailed information on the available drivers, please see page 6.

Sensors - Selux offers a variety of integral sensor options. For details and specifications, please see page 9.

Emergency - There are multiple emergency options available - emergency circuit, remote micro inverter, and integral battery. All options compliant with UL 924 listed emergency luminaire. Please consult factory for use of sensors with emergency option. For more details on EC and EM options, see page 8.

Thermal Performance:

Ambient Operating Temperature - Luminaires are suitable for maximum ambient temperature of 35°C (95°F) for all drivers.

Luminaires are suitable for minimum ambient temperatures of -40°C (-40°F) for DIM, DIL, DED, D01, and DL01 drivers; 0°C (32°F) for DC2 and DE1 drivers.

Luminaire Finish:

Powder Coat - All Selux luminaires are finished in high quality polyester powder coating in our Tiger Drylac certified facility and are tested in accordance with test specifications for coatings from ASTM and PCI.

All products undergo a five stage intensive pretreatment process where product is thoroughly cleaned, phosphated, and sealed. Selux powder coated products provide excellent salt and humidity resistance as well as ultra violet resistance for color retention.

Standard colors for Piix™ MRC are White (WH), Semi-Matte Black (BL), and Silver (SV). Selux premium colors (SP) are available, please specify from your Selux color selection guide.

Warranty:

5 Year Limited LED Luminaire Warranty - Selux offers a 5 Year Limited Warranty to the original purchaser that the Piix™ MRC luminaire shall be free from defects in material and workmanship for up to five (5) years from date of shipment. This limited warranty covers the LED driver and LED light engine when installed according to Selux instructions and operated within the Ambient Temperature. For additional details and exclusions, see "Selux Terms and Condition of Sale."

Certifications and Compliance:

NRTL - For dry locations (i.e. cULus, cCSAus)
NRTL - For damp locations with the clear or diffuse secondary optics (i.e. cULus, cCSAus)

ARRA Compliant
ADA Compliant when mounted parallel to the wall
RoHS Compliant

Cable Mounting (C)

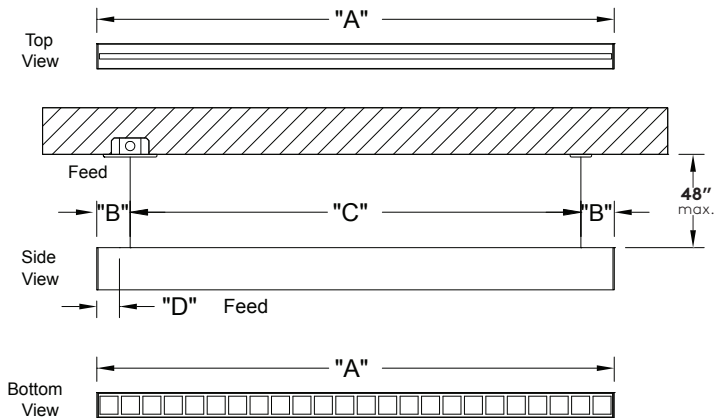

Cable Mounting (C)

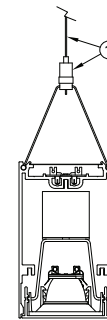

1. $\varnothing \frac{3}{64}$ " Aircraft Cable with chrome gripper for easy adjustment (48" max. from ceiling to luminaire).

Cable Mounting (C) - Dimensions								
Nominal Length	"A" Housing Length		* "B" (Ref.) Typical Mounting Distance for Normal Installation		"C" Mid. Suspension		"D" Feed Location	
	Feet/Inch	MM	Feet/Inch	MM	Feet/Inch	MM	Feet/Inch	MM
02 (2 ft.)	2' - 0 $\frac{5}{16}$ "	617	0' - 2 $\frac{1}{8}$ "	54	1' - 8 $\frac{1}{16}$ "	509	0' - 1 $\frac{1}{8}$ "	29
03 (3 ft.)	3' - 0 $\frac{5}{16}$ "	922	0' - 3 $\frac{1}{8}$ "	79	2' - 6 $\frac{1}{16}$ "	763	0' - 2 $\frac{1}{8}$ "	54
04 (4 ft.)	4' - 0 $\frac{5}{16}$ "	1227	0' - 3 $\frac{1}{8}$ "	79	3' - 6 $\frac{1}{16}$ "	1068	0' - 2 $\frac{1}{8}$ "	54
05 (5 ft.)	5' - 0 $\frac{5}{16}$ "	1531	0' - 3 $\frac{1}{8}$ "	79	4' - 6 $\frac{1}{16}$ "	1373	0' - 2 $\frac{1}{8}$ "	54
06 (6 ft.)	6' - 0 $\frac{5}{16}$ "	1836	0' - 3 $\frac{1}{8}$ "	79	5' - 6 $\frac{1}{16}$ "	1677	0' - 2 $\frac{1}{8}$ "	54
07 (7 ft.)	7' - 0 $\frac{5}{16}$ "	2141	0' - 3 $\frac{1}{8}$ "	79	6' - 6 $\frac{1}{16}$ "	1982	0' - 2 $\frac{1}{8}$ "	54
08 (8 ft.)	8' - 0 $\frac{5}{16}$ "	2446	0' - 3 $\frac{1}{8}$ "	79	7' - 6 $\frac{1}{16}$ "	2287	0' - 2 $\frac{1}{8}$ "	54

*Dimension(s) rounded to the nearest $\frac{1}{16}$ " with a $\pm \frac{1}{16}$ " (1mm) tolerance.

PXLDI Cable(C) Suspension Detail (Feed location(s) only)

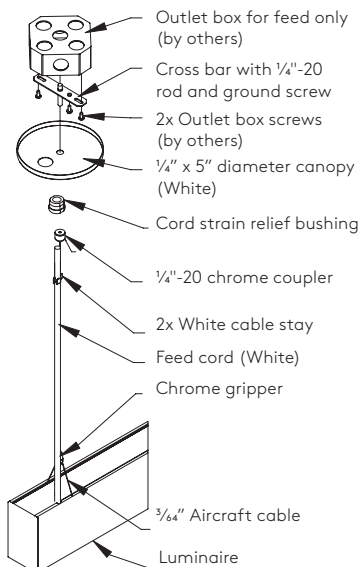

PXLDI Cable (C) Suspension Detail (Non-Feed location(s) only)

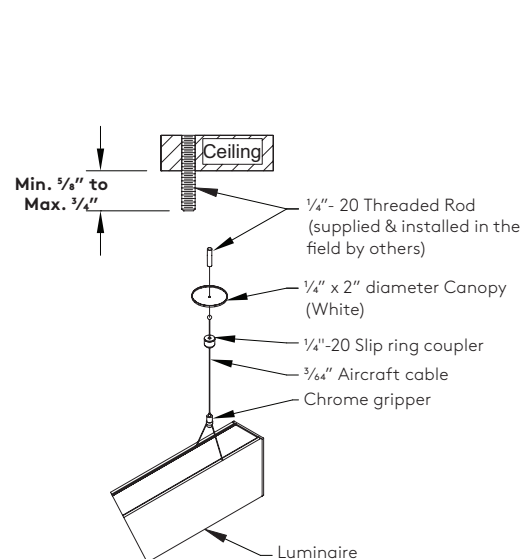

Stem Mounting (S & RS)

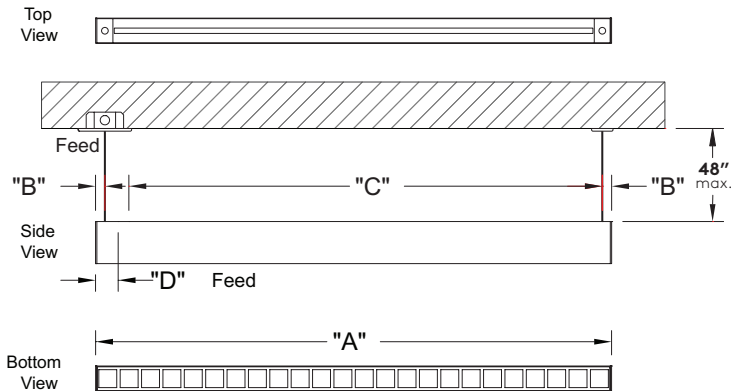

Stem Mounting (S & RS)

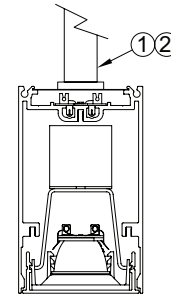

1. $\varnothing \frac{5}{8}$ " Swivel Stem provides 30° swivel and **can be cut in field** (48" max. from ceiling to luminaire).
2. $\varnothing \frac{5}{8}$ " Rigid Stem is fixed and is **not able to be cut/adjusted in field** (48" max. from ceiling to luminaire).

Nominal Length	Swivel (S) & Rigid Stem (RS) Mountings - Dimensions							
	"A" Housing Length		* "B" (Reference) End Suspensions		"C" Mid. Suspension		"D" Feed Location	
	Feet/Inch	MM	Feet/Inch	MM	Feet/Inch	MM	Feet/Inch	MM
02 (2 ft.)	2' - 0 $\frac{5}{16}$ "	617	0' - 0 $\frac{7}{8}$ "	22	1' - 10 $\frac{9}{16}$ "	573	0' - 0 $\frac{7}{8}$ "	22
03 (3 ft.)	3' - 0 $\frac{5}{16}$ "	922	0' - 0 $\frac{7}{8}$ "	22	2' - 10 $\frac{9}{16}$ "	877	0' - 0 $\frac{7}{8}$ "	22
04 (4 ft.)	4' - 0 $\frac{5}{16}$ "	1227	0' - 0 $\frac{7}{8}$ "	22	3' - 10 $\frac{9}{16}$ "	1182	0' - 0 $\frac{7}{8}$ "	22
05 (5 ft.)	5' - 0 $\frac{5}{16}$ "	1531	0' - 0 $\frac{7}{8}$ "	22	4' - 10 $\frac{9}{16}$ "	1487	0' - 0 $\frac{7}{8}$ "	22
06 (6 ft.)	6' - 0 $\frac{5}{16}$ "	1836	0' - 0 $\frac{7}{8}$ "	22	5' - 10 $\frac{9}{16}$ "	1792	0' - 0 $\frac{7}{8}$ "	22
07 (7 ft.)	7' - 0 $\frac{5}{16}$ "	2141	0' - 0 $\frac{7}{8}$ "	22	6' - 10 $\frac{9}{16}$ "	2097	0' - 0 $\frac{7}{8}$ "	22
08 (8 ft.)	8' - 0 $\frac{5}{16}$ "	2446	0' - 0 $\frac{7}{8}$ "	22	7' - 10 $\frac{9}{16}$ "	2401	0' - 0 $\frac{7}{8}$ "	22

*Dimension(s) rounded to the nearest $\frac{1}{16}$ " with a $\pm \frac{1}{16}$ (1mm) tolerance.

PXLDI Swivel Stem (S) Suspension Detail
(feed wires through stem supplied by Selux)

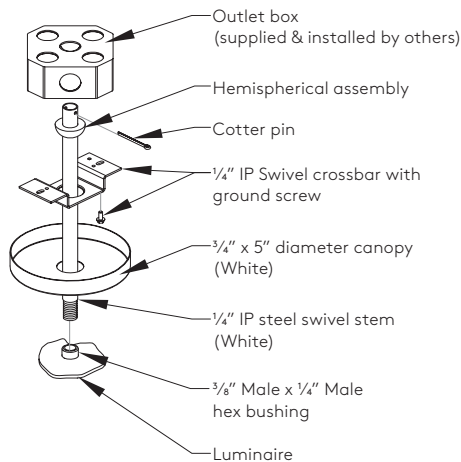

PXLDI Rigid Stem (RS) Suspension Detail
(feed wires through stem supplied by Selux)

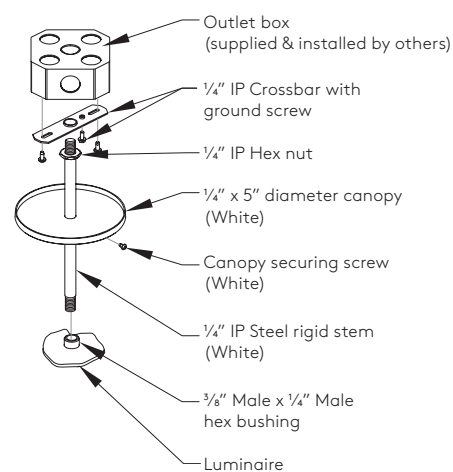

Wall Mounting (W)

For patterns and configurations that include a wall mounted option, please see page 9 for details.

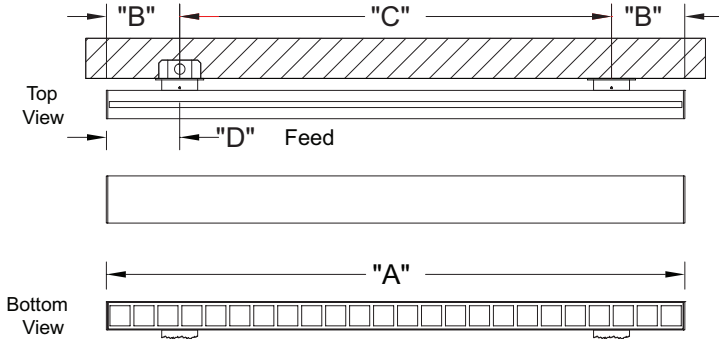

Wall (W) - Dimensions								
Nominal Length	"A" Housing Length		* "B" (Reference) End Suspensions		"C" Mid. Suspension		"D" Feed Location	
	Feet/Inch	mm	Feet/Inch	mm	Feet/Inch	mm	Feet/Inch	mm
02 (2 ft.)	2' - 0 5/16"	617	0' - 3 1/8"	79	1' - 6 1/16"	458	0' - 3 1/8"	79
03 (3 ft.)	3' - 0 5/16"	922	0' - 6 1/8"	156	2' - 0 1/16"	611	0' - 6 1/8"	156
04 (4 ft.)	4' - 0 5/16"	1227	0' - 6 1/8"	156	3' - 0 1/16"	915	0' - 6 1/8"	156
05 (5 ft.)	5' - 0 5/16"	1531	0' - 6 1/8"	156	4' - 0 1/16"	1220	0' - 6 1/8"	156
06 (6 ft.)	6' - 0 5/16"	1836	0' - 6 1/8"	156	5' - 0 1/16"	1525	0' - 6 1/8"	156
07 (7 ft.)	7' - 0 5/16"	2141	0' - 6 1/8"	156	6' - 0 1/16"	1830	0' - 6 1/8"	156
08 (8 ft.)	8' - 0 5/16"	2446	0' - 6 1/8"	156	7' - 0 1/16"	2135	0' - 6 1/8"	156

*Dimension(s) rounded to the nearest 1/16" with a ± 1/16" (1mm) tolerance.

Wall Mount (W)
(Covers a 2x4 J-box only)

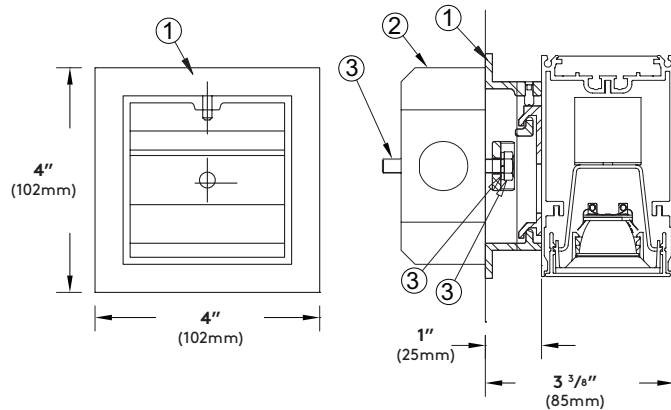

1. Aluminum wall bracket (by Selux).
2. 4" x 4" J-box at feed location (supplied and installed by others).
3. 1/4"-20 Threaded rod, 1/4"-20 lock washer and 1/4"-20 nut required to anchor the wall bracket. Mounting hardware supplied and installed to code by others.

Drivers:

0-10V linear dimming (DIM)

Luminaires supplied with drivers offering the capability of either normal switched operation or 0-10V dimming for linear dimming curve. Fixtures ship wired for dimming. For on/off functionality, simply cap the dimming leads. Minimum dimming level preset at factory to 1%.

0-10V logarithmic eldoLED ECOdrive dimming (DIL)

Luminaires supplied with drivers offering the capability of either normal switched operation or 0-10V dimming for logarithmic dimming curve. Fixtures ship wired for dimming. For on/off functionality, simply cap the dimming leads. Minimum dimming level preset at factory to 1%.

eldoLED ECOdrive DALI dimming (DED)

Luminaires supplied with ECOdrive DALI dimming driver for logarithmic dimming curve. Minimum dimming level preset at factory to 1%. For “dim to dark” (down to 0.1%), please consult factory.

eldoLED SOLOdrive 0-10V linear dimming (D01)

Luminaires supplied with SOLOdrive 0-10V dimming driver for linear dimming curve. Minimum dimming level preset at factory to 0.1% and “dim to dark”.

eldoLED SOLOdrive 0-10V logarithmic dimming (DL01)

Luminaires supplied with SOLOdrive 0-10V dimming driver for logarithmic dimming curve. Minimum dimming level preset at factory to 0.1% and “dim to dark”.

LUTRON 2-wire dimming (DC2)

Luminaires supplied with Hi-Lume 2-wire dimming driver (120V only) programmed for Constant Current Reduction (CCR). For Pulse Width Modulation (PWM) dimming, please consult factory. Minimum dimming level down to 1%.

LUTRON EcoSystem dimming (DE1)

Luminaires supplied with Hi-Lume EcoSystem (4 wire, digital link) dimming driver programmed for Constant Current Reduction (CCR). Minimum dimming level down to 1% with SoftOn/FadeToBlack.

* For control recommendations, please contact driver manufacturer

* Driver Quantity								
Fixture Length								
Dimming Protocol	2 ft.	3 ft.	4 ft.	5 ft.	6 ft.	7 ft.	8 ft.	RUN
DIM, DIL, DC2, DE1	1	2	2	4	4	4	4	Approximately 1 drive per 4 ft.
DED, D01, DL01	1	1	2	3	4	4	4	Approximately 1 drivers per 4 ft.

*For inrush and control current, please refer to the driver manufacturers' spec sheets.

Wiring Diagrams

- 0-10V linear (DIM)
- 0-10V logarithmic eldoLED ECOdrive (DIL)
- DALI logarithmic eldoLED ECOdrive (DED)
- 0-10V linear eldoLED SOLOdrive (D01)
- 0-10V logarithmic eldoLED SOLOdrive (DL01)

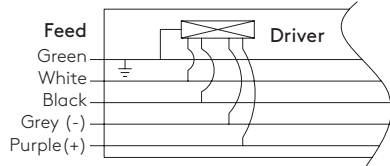

Standard Wiring supplied for all drivers	Green = Ground White = Neutral Black = Hot
- The following wire(s) are in addition to the standard above -	
DIM, DIL, DED, D01, DL01	Gray = (-) DALI or 0-10V Dimming Control Purple = (+) DALI or 0-10V Dimming Control
DC2	No additional wires
DE1	Violet = "E1" Digital Link Dimming Control Violet/White = "E2" Digital Link Dimming Control

Lutron 2-Wire (DC2)

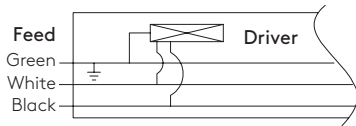

Lutron EcoSystem (DE1)

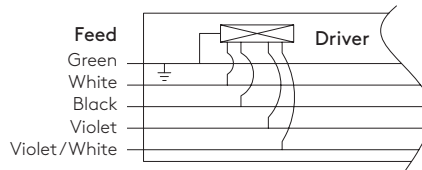

Sensor Wiring Diagrams

Enlighted

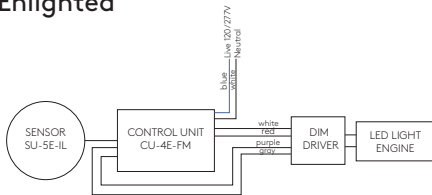

Sensor Switch

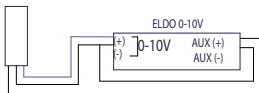

Lutron Vive

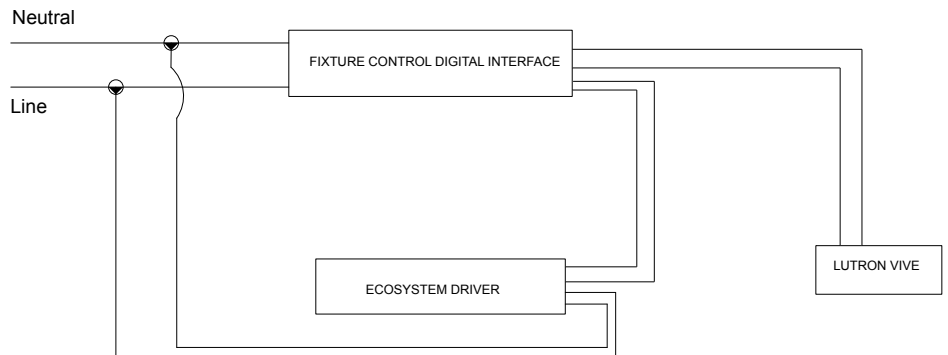

Fuse (FS) - Fusing, luminaires supplied with a in-line fuse located on the hot wire for each feed. (supplied with an 8A slow burn fuse).

Separate Switching (SS) - Luminaires available with separately switched 4' (nominal) sections starting at 7' and up. Luminaire is intended to be wired to the same panel/breaker (not intended for Emergency use).

- * To specify this option, the number of separately switched sections and locations of these sections must be provided at time of order.
- * If the project requires different separate switching than outlined above please consult the factory.
- * For Separate Switching with sensors, please consult factory.

Emergency Circuit (EC) - Luminaires with EC option are compliant to UL 924 listed emergency luminaire. EC luminaires are intended to be wired to separate panels/breakers for emergency use. See install instructions for proper wiring.

Direct fixtures are available for Emergency battery use in 4' and ≥6'. Due to size constraints, EM is not available in 5' fixtures.

For 2' to 6' nominal luminaires, the entire fixture is wired for operation on emergency circuit.

For individual fixtures, emergency option will illuminate the first 4' section of fixture. For continuous runs, please consult factory to advise on 4' section intended for emergency use.

For 7' and up nominal luminaires, the first 4' nominal length is wired for operation by a separate dedicated emergency circuit by default to meet the required "Life Safety Code" (NFPA 101).

For fixtures >8' or if a different configuration is needed, please consult factory.

If a different configuration is needed, please consult factory.

Emergency test switch is located in faceplate adjacent to the length of fixture wired for emergency.

Note: Wiring may vary slightly due to on site conditions or local codes. Please follow all safety installation protocols contained within install instructions when installing luminaire.

Emergency battery option is UNV for use with 120V or 277V and is not available for 347V.

Emergency Battery (EM) - Luminaires with EM option compliant to UL 924 listed emergency luminaire. The EM battery is located integral to fixture and is factory pre-wired. See install instructions for proper wiring.

- * Please note battery pack requires an unswitched hot.
- * For EM with sensors, please consult factory.
- * If a different configuration is needed, please consult factory.

In the event of an emergency, EM battery will illuminate a 4' section at 12W (constant) for 90 minutes at 25°C. Recharge time is 24 hours.

Note: Wiring may vary slightly due to on site conditions or local codes. Please follow all safety installation protocols contained within install instructions when installing luminaire.

Joiner System - standard for Runs and Configurations

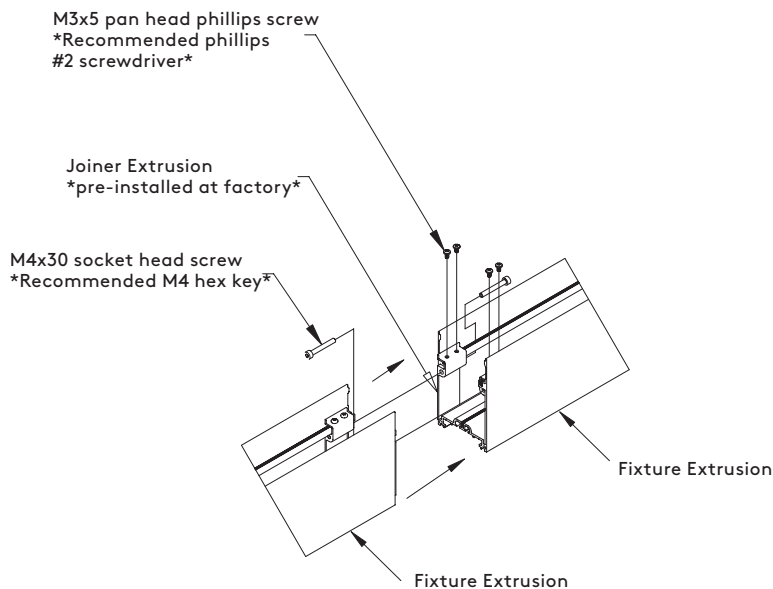

Sensor Ordering Chart		
Quantity	Sensor	Settings*
x Number of Sensors	E Enlighted SU-5E-IL S Sensor Switch MSD EZ V Lutron Vive DFCSJ	1 Daylight 2 Occupancy/Vacancy 3 Daylight/Occupancy/Vacancy * Settings not available with Enlighted

Enlighted SU-5E-IL (E)

Enlighted Micro Sensor SU-5E-IL (Independent Lighting) provided as standard with an Enlighted CU-4E-FM Fixture Mount Control Unit integral to fixture. If SU-5E-CL (Connected Lighting) or SU-5E-IoT (Internet of Things) is desired, please contact factory. Occupancy/vacancy, thermal, daylight sensing plus Tunable White, Room & Zone control, Internet of Things (IoT) data collection and reporting control. For full details, please see SU-5E-(IoT/CL/IL) spec sheet on the Enlighted website. Must be paired with a 0-10V driver with auxiliary (DIM driver selection). Commissioning by Enlighted.

*Sensor can control up to 5 drivers. Please refer to driver quantity chart on page 6. Multiple sensors may be required for longer lengths.

Sensor Switch MSD EZ (S)

Occupancy/vacancy and daylight harvesting. For full functionality and programming options, select settings option 3. If a different settings option is selected, other settings may be unavailable. For full details, please see MSD EZ spec sheets on the Sensor Switch website. Must be paired with DIM driver selection. Manual control of dimming not available with MSD EZ sensor.

*Sensor can control up to 30 drivers. Please refer to driver quantity chart on page 6. Multiple sensors may be required for longer lengths.

Lutron Vive DFCSJ (V)

The DFCSJ-OEM-OCC provides the capabilities of daylight harvesting and occupancy/vacancy sensing. When integrated with the DFC-OEM-DBI (Fixture Control Digital Link Interface), the sensor is wirelessly compatible with the DE1 Lutron EcoSystem driver. Commissioning by certified Lutron technician.

*Vive DFCSJ sensor can control up to a maximum of five (5) drivers per sensor. Please refer to driver chart on page 6. Multiple sensors may be required for longer lengths.

	Occupancy	Vacancy	Daylight Harvesting	Driver Compatibility
Enlighted SU-5E-IL (E)	✓	✓	✓	DIM
Sensor Switch MSD EZ (S)	✓	✓	✓	DIM
Lutron Vive DFCSJ (V)	✓	✓	✓	DE1

Please contact controls manufacturer for details prior to specifying.

Factory Presets - Sensors come from the sensor manufacturer with factory presets for each of the settings in above chart. Please see sensor manufacturers' spec sheets for details on presets and re-programming.

Commissioning - Commissioning of sensors and installation by others. Contact sensor manufacturer for details and costs associated with commissioning the system prior to specification of sensors.

Standard Sensor Placement - for other placement options, please consult factory. For functionality and limitations, please see sensor details above.

Qty 1 Sensor - Beginning



Qty 2 Sensor - Beginning and End (9' fixtures and longer)



Qty 3+ Sensor - For spacing between sensors, please consult the sensor manufacturer.

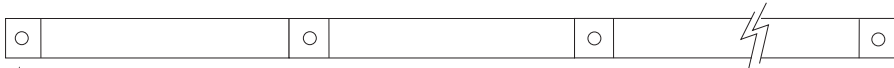

↑
Beginning of Run

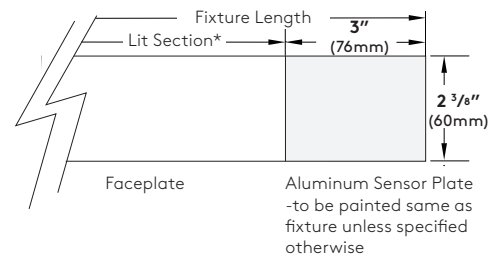

*Lit section will be the fixture length minus 3" for sensor plate.

- Notes: 1. For spacing between sensors, please consult the sensor manufacturer.
- 2. Exact sensor placement and coverage will be defined by approved factory drawing.
- 3. Sections controlled by sensors may not be symmetrical - consult factory for layout.

Standard Direct/Indirect (PXLDI) shapes/configurations:

Listed below are the minimum lengths and details for standard shapes. These standard shapes can be combined with each other and/or the standard luminaire lengths, ensuring full even illumination. If you have any questions, please consult the factory.

The minimum standard lengths for "L" shapes:

- L9 or V9 open shapes is 2' x 2' nominal (example: leg, 90, leg)
- L9 or V9 closed shapes is 4' x 4' nominal (example: 90, leg, 90)
- L9 & V9 corners can be joined directly together to provide a 4' x 4' nominal shape.

* L9 corners are not lit.

* For sensors in configurations, please consult factory.

For patterns and configurations that include a wall mounted option, please consult factory to identify location, on which side of housing and spacing of brackets required.

The minimum standard lengths for "T" & "X" shapes:

- T9 = 2' nominal on the short leg and 4' nominal on the long side
- X9 = 4' nominal for either direction

* T9 and X9 direct corners are lit with an MRC in the corner.

Project Specific Direct/Indirect shapes/configurations:

Selux is capable of supplying a wide range of project solutions including different shapes, angles, and sizes to meet the project requirements. Due to the complex nature of these project specific layout(s) we ask that you please consult the factory with the project requirements for review.

L9 - Horizontal Center

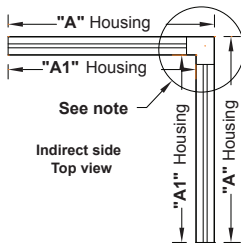

T9 - "T" Section

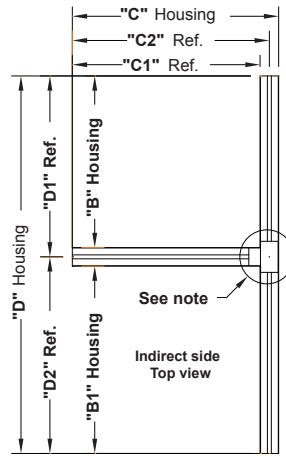

X9 - "X" Section

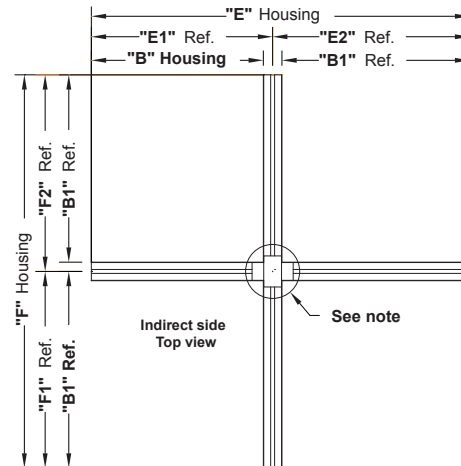

Note: The Indirect side of the shapes have small unlit sections for certain mounting types (consult factory).

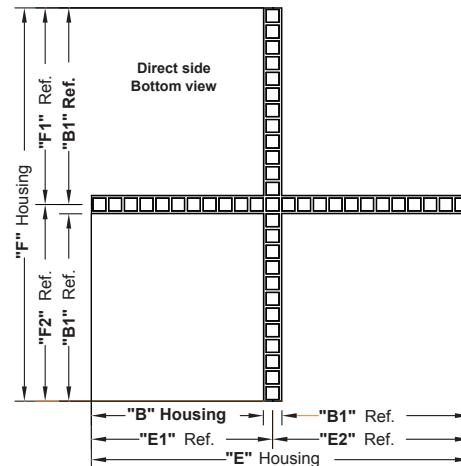
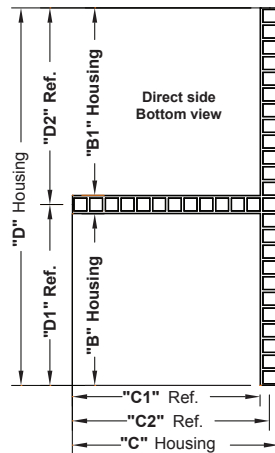
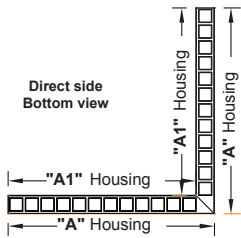

Standard Direct/Indirect (PXLDI) shapes/configurations:

Direct/Indirect PXLDI Corner and Section - Dimensions						
Nominal Length	L9		T9		X9	
	Feet/Inch	MM	Feet/Inch	MM	Feet/Inch	MM
"A" Housing (Outside)	2' - 2 3/16"	666	N/A	N/A	N/A	N/A
"A1" Housing (Inside)	1' - 11 13/16"	606	N/A	N/A	N/A	N/A
"B" Housing	N/A	N/A	1' - 9 13/16"	555	1' - 11 13/16"	606
* "B1" Ref.	N/A	N/A	1' - 11 13/16"	606	1' - 11 13/16"	606
"C" Housing	N/A	N/A	2' - 2 3/16"	666	N/A	N/A
* "C1" Ref.	N/A	N/A	1' - 11 13/16"	606	1' - 9 13/16"	555
* "C2" Ref.	N/A	N/A	2' - 1"	636	N/A	N/A
"D" Housing	N/A	N/A	4' - 0 1/16"	1220	N/A	N/A
* "D1" Ref.	N/A	N/A	1' - 11"	585	N/A	N/A
* "D2" Ref.	N/A	N/A	2' - 1"	636	N/A	N/A
"E" Housing	N/A	N/A	N/A	N/A	4' - 0 1/16"	1220
* "E1" Ref.	N/A	N/A	N/A	N/A	1' - 11"	585
* "E2" Ref.	N/A	N/A	N/A	N/A	2' - 1"	636
"F" Housing	N/A	N/A	N/A	N/A	4' - 2 1/16"	1271
* "F1" Ref.	N/A	N/A	N/A	N/A	2' - 1"	636
* "F1" Ref.	N/A	N/A	N/A	N/A	2' - 1"	636

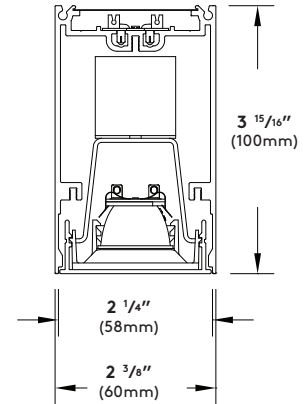

* Dimension(s) rounded to the nearest 1/16" (1mm) tolerance.

Photometry

Direct - 20° Optics / Clear Lens / 44W / 3500K

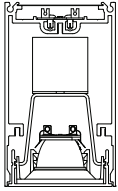

Catalog #: PXL-1B45-935-20-CL-X-04-XX-UNV
Report #: 12546460.01
Delivered Lumens: 2946
Input Watts: 43.6
Efficacy: 67 lm/W
CCT: 4000K
CRI: 93.7

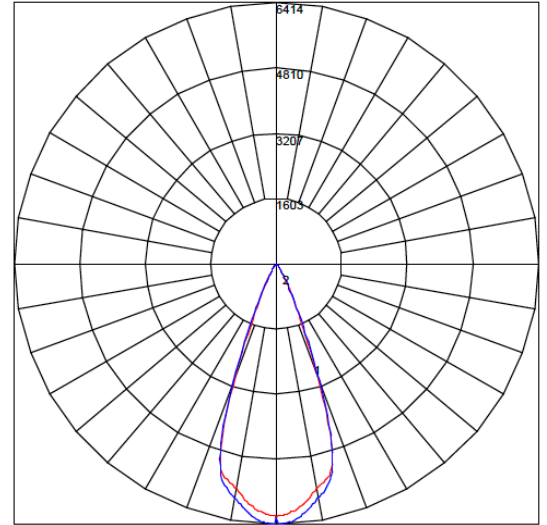

Maximum Candela = 6413.825 Located At Horizontal Angle = 0, Vertical Angle = .5
1 - Vertical Plane Through Horizontal Angles (90 - 270)
2 - Vertical Plane Through Horizontal Angles (0 - 180)

Direct - 35° Optics / Clear Lens / 44W / 3500K

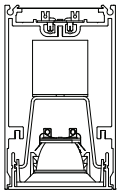

Catalog #: PXL-1B45-935-35-CL-X-04-XX-UNV
Report #: 12546460.09
Delivered Lumens: 3361
Input Watts: 43.6
Efficacy: 77 lm/W
CCT: 4000K
CRI: 93.7

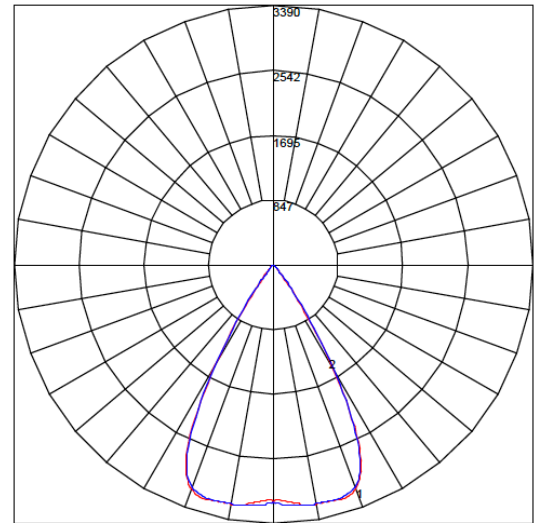

Maximum Candela = 3389.969 Located At Horizontal Angle = 45, Vertical Angle = 23.5
1 - Vertical Plane Through Horizontal Angles (90 - 270)
2 - Vertical Plane Through Horizontal Angles (0 - 180)

Direct - 50° Optics / Clear Lens / 44W / 3500K

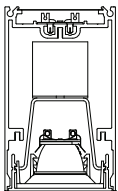

Catalog #: PXL-1B45-935-50-CL-X-04-XX-UNV
Report #: 12546460.05
Delivered Lumens: 3507
Input Watts: 43.6
Efficacy: 80 lm/W
CCT: 4000K
CRI: 93.7

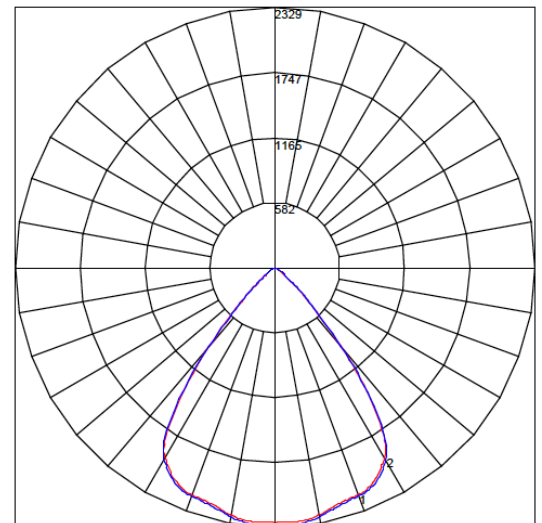

Maximum Candela = 2329.063 Located At Horizontal Angle = 0, Vertical Angle = .5
1 - Vertical Plane Through Horizontal Angles (90 - 270)
2 - Vertical Plane Through Horizontal Angles (0 - 180)

Photometry

Direct - 20° Optics / Hexcell Louver / 44W / 3500K

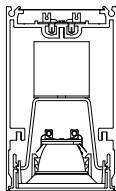

Catalog #: PXL-1B45-935-20-HX-X-04-XX-UNV
Report #: 12546460.07
Delivered Lumens: 1386
Input Watts: 43.6
Efficacy: 32 lm/W
CCT: 4000K
CRI: 93.7

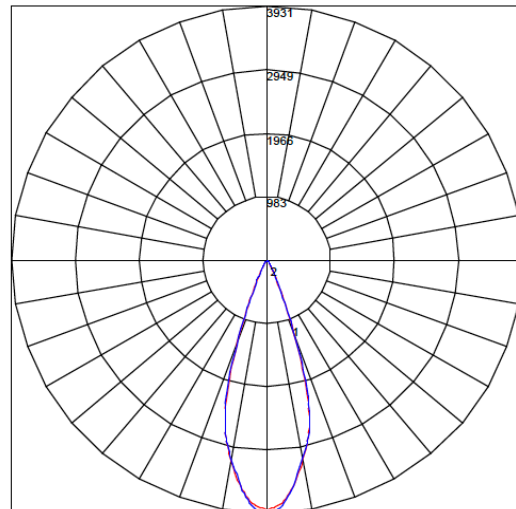

Maximum Candela = 3931.378 Located At Horizontal Angle = 0, Vertical Angle = .5
1 - Vertical Plane Through Horizontal Angles (90 - 270)
2 - Vertical Plane Through Horizontal Angles (0 - 180)

Direct - 35° Optics / Hexcell Louver / 44W / 3500K

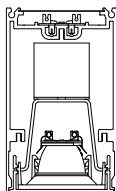

Catalog #: PXL-1B45-935-35-HX-X-04-XX-UNV
Report #: 12546460.06
Delivered Lumens: 1219
Input Watts: 43.6
Efficacy: 28 lm/W
CCT: 4000K
CRI: 93.7

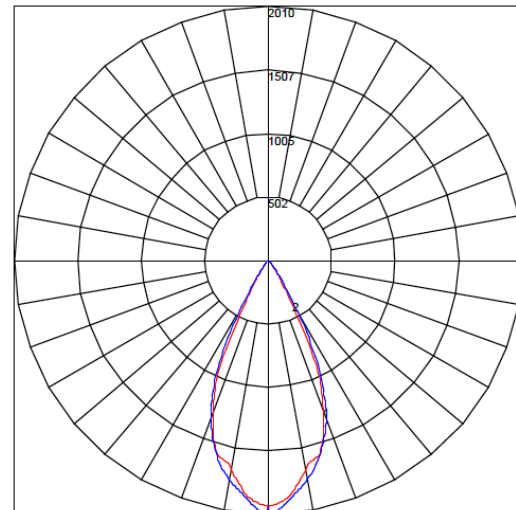

Maximum Candela = 2009.513 Located At Horizontal Angle = 0, Vertical Angle = .5
1 - Vertical Plane Through Horizontal Angles (90 - 270)
2 - Vertical Plane Through Horizontal Angles (0 - 180)

Direct - 50° Optics / Hexcell Louver / 44W / 3500K

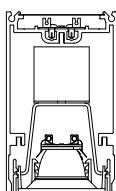

Catalog #: PXL-1B45-935-50-HX-X-04-XX-UNV
Report #: 12546460.03
Delivered Lumens: 1005
Input Watts: 43.6
Efficacy: 23 lm/W
CCT: 4000K
CRI: 93.7

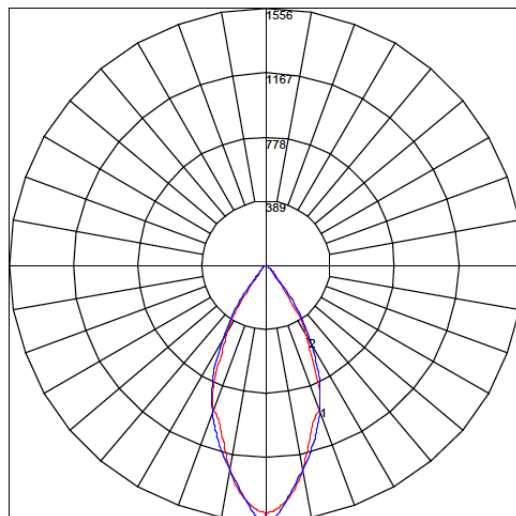

Maximum Candela = 1555.752 Located At Horizontal Angle = 0, Vertical Angle = .5
1 - Vertical Plane Through Horizontal Angles (90 - 270)
2 - Vertical Plane Through Horizontal Angles (0 - 180)

Photometry

Direct - 20° Optics / 30% Diffuse Lens / 44W / 3500K

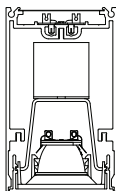

Catalog #: PXL-1B45-935-20-DF-X-04-XX-UNV
Report #: 12546460.04
Delivered Lumens: 2495
Input Watts: 43.6
Efficacy: 57lm/W
CCT: 4000K
CRI: 93.7

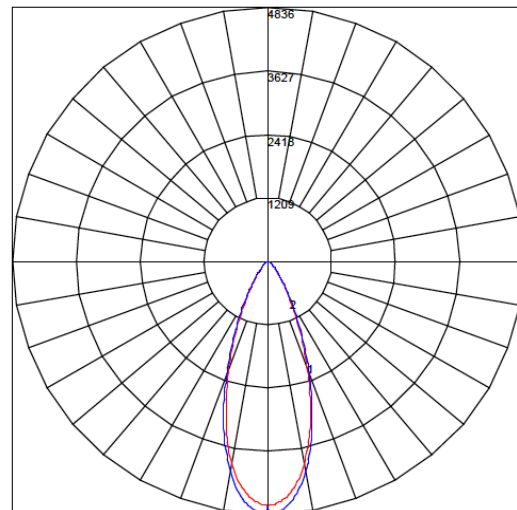

Maximum Candela = 4836.161 Located At Horizontal Angle = 0, Vertical Angle = .5
1 - Vertical Plane Through Horizontal Angles (90 - 270)
2 - Vertical Plane Through Horizontal Angles (0 - 180)

Direct - 35° Optics / 30% Diffuse Lens / 44W / 3500K

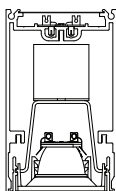

Catalog #: PXL-1B45-935-35-DF-X-04-XX-UNV
Report #: 12546460.02
Delivered Lumens: 2768
Input Watts: 43.6
Efficacy: 63lm/W
CCT: 4000K
CRI: 93.7

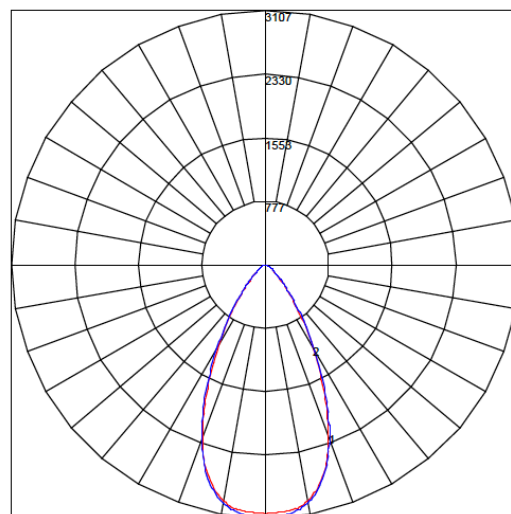

Maximum Candela = 3106.939 Located At Horizontal Angle = 0, Vertical Angle = .5
1 - Vertical Plane Through Horizontal Angles (90 - 270)
2 - Vertical Plane Through Horizontal Angles (0 - 180)

Direct - 50° Optics / 30% Diffuse Lens / 44W / 3500K

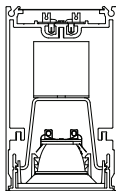

Catalog #: PXL-1B45-935-50-DF-X-04-XX-UNV
Report #: 12546460.08
Delivered Lumens: 2875
Input Watts: 43.6
Efficacy: 66 lm/W
CCT: 4000K
CRI: 93.7

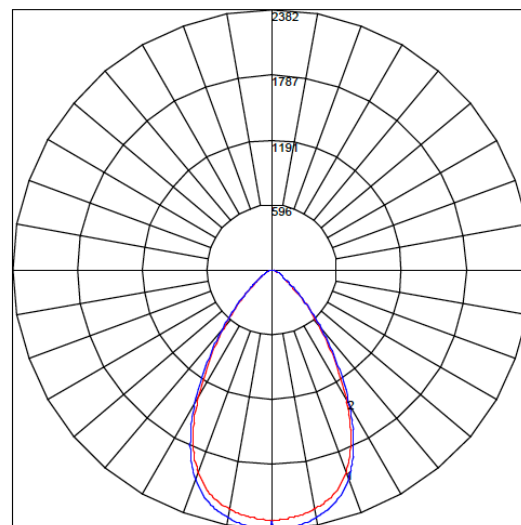

Maximum Candela = 2382.017 Located At Horizontal Angle = 0, Vertical Angle = .5
1 - Vertical Plane Through Horizontal Angles (90 - 270)
2 - Vertical Plane Through Horizontal Angles (0 - 180)

Photometry

Direct - 20° Optics / (XX) No Lens / 44W / 3500K

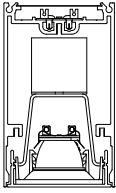

Catalog #: PXL-1B45-935-20-XX-X-04-XX-UNV
Report #: 12472594.01
Delivered Lumens: 3429
Input Watts: 43.6
Efficacy: 79 lm/W
CCT: 4000K
CRI: 93.7

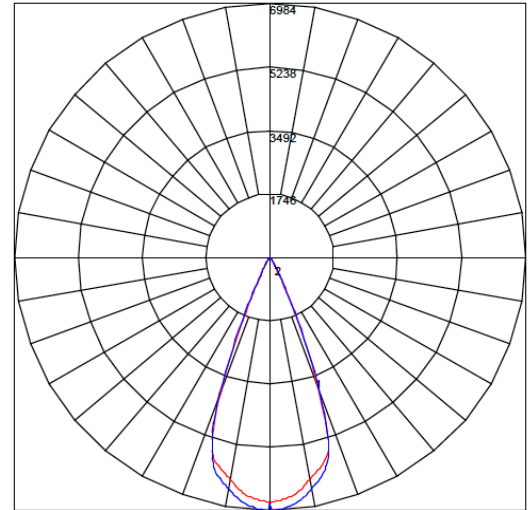

Maximum Candela = 6984.45 Located At Horizontal Angle = 0, Vertical Angle = -5
1 - Vertical Plane Through Horizontal Angles (90 - 270)
2 - Vertical Plane Through Horizontal Angles (0 - 180)

Direct - 35° Optics / (XX) No Lens / 44W / 3500K

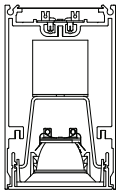

Catalog #: PXL-1B45-935-35-XX-X-04-XX-UNV
Report #: 12472594.02
Delivered Lumens: 3995
Input Watts: 43.6
Efficacy: 92 lm/W
CCT: 4000K
CRI: 93.7

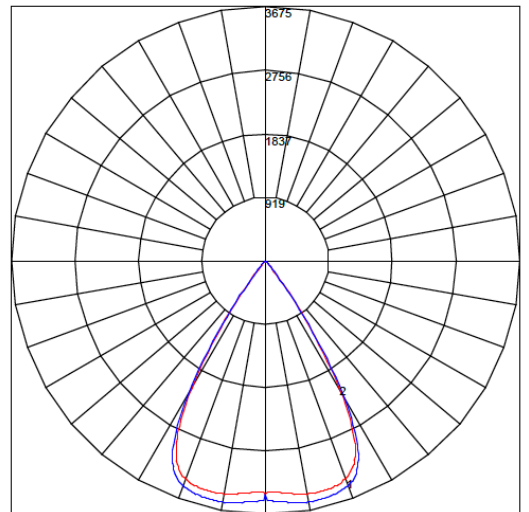

Maximum Candela = 3674.825 Located At Horizontal Angle = 45, Vertical Angle = 24.5
1 - Vertical Plane Through Horizontal Angles (90 - 270)
2 - Vertical Plane Through Horizontal Angles (0 - 180)

Direct - 50° Optics / (XX) No Lens / 44W / 3500K

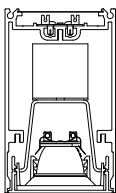

Catalog #: PXL-1B45-935-50-XX-X-04-XX-UNV
Report #: 12472594.04
Delivered Lumens: 4199
Input Watts: 43.6
Efficacy: 96 lm/W
CCT: 4000K
CRI: 93.7

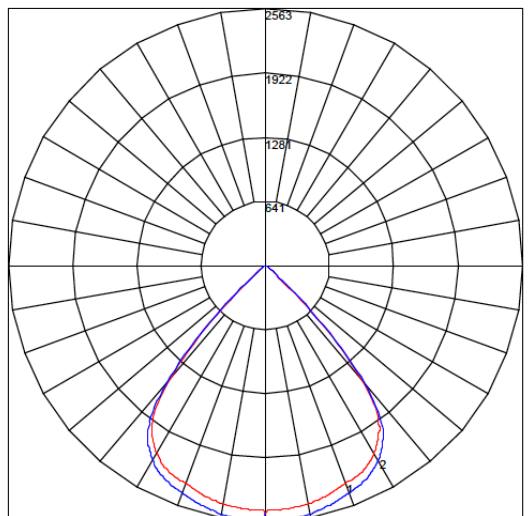

Maximum Candela = 2562.791 Located At Horizontal Angle = 0, Vertical Angle = -5
1 - Vertical Plane Through Horizontal Angles (90 - 270)
2 - Vertical Plane Through Horizontal Angles (0 - 180)

Photometry

Indirect – Diffuse lens / 35W / 3500K

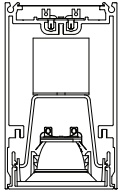

Catalog #: PXLDI-XXXX-1C35-935-XX-ID-X-04-XX-UNV
Report #: 12472594.08
Delivered Lumens: 4158
Input Watts: 35
Efficacy: 112 lm/W
CCT: 4000K
CRI: 93.7

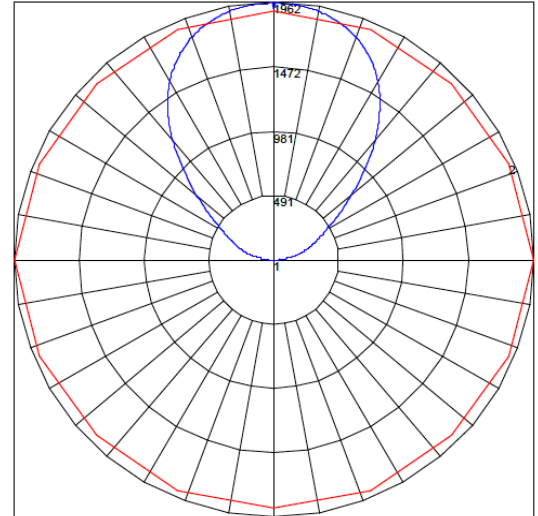

Maximum Candela = 1962 Located At Horizontal Angle = 0, Vertical Angle = 179
1 - Vertical Plane Through Horizontal Angles (0 - 180) (Through Max. Cd.)
2 - Horizontal Cone Through Vertical Angle (179) (Through Max. Cd.)

Indirect – Batwing lens / 35W / 3500K

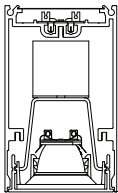

Catalog #: PXLDI-XXXX-1C35-935-XX-IB-X-04-XX-UNV
Report #: 12546460.13A
Delivered Lumens: 4273
Input Watts: 35
Efficacy: 122 lm/W
CCT: 4000K
CRI: 93.7

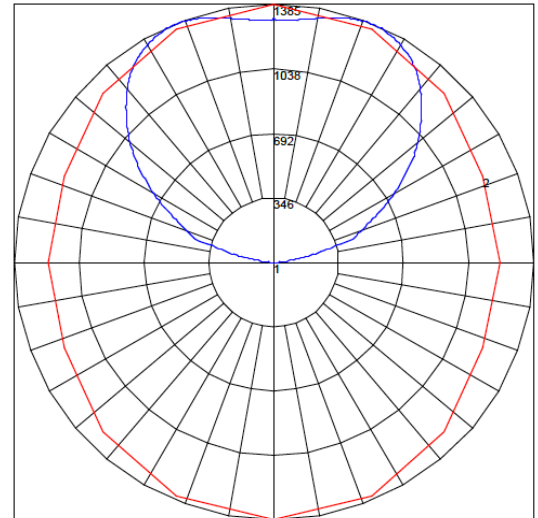

Maximum Candela = 1384.56 Located At Horizontal Angle = 90, Vertical Angle = 157.5
1 - Vertical Plane Through Horizontal Angles (90 - 270) (Through Max. Cd.)
2 - Horizontal Cone Through Vertical Angle (157.5) (Through Max. Cd.)

Piix™ Linear Direct/Indirect	
CCT Multiplier*	
4000K	1.000
3500K	0.913
3000K	0.903
2700K	0.903
Direct Lens Multiplier*	
CL	0.84
HX	0.31
DF	0.69
XX	1.00
Indirect Lens Multiplier**	
ID	1.00
IB	0.95

Note: Due to the amount of variation of lens/distribution options possible, please import and align the individual, direct, and indirect IES files and group within the photometric program you are using.

CCT multipliers apply to the photometry, IES files, and per foot values listed on page 1 (light engine).

Light engine and lens multiplier supplied for per foot values listed on page 1 (light engine).

*Values calculated from a 4' fixture at 4000K, 90+ CRI using 35° reflector and DIM driver.

** Values calculated from a 4' fixture at 3500K, 90+ CRI using ID optic and DIM driver.